

INTERIOR DESIGN
& ARCHITECTURE
PORTFOLIO

AVA GRACE KOELE



ABOUT ME

MY NAME IS AVA GRACE KOELE AND I AM PASSIONATE ABOUT MAKING A MEANINGFUL IMPACT IN PEOPLE'S LIVES THROUGH BEAUTIFUL, FUNCTIONAL, AND HUMAN-CENTERED INTERIOR DESIGN. MY INTEREST IN DESIGN AND ARCHITECTURE BEGAN AT A YOUNG AGE WHEN I VISITED MY GREAT GRANDMOTHER IN A REHABILITATION CENTER. I WAS STRUCK BY HOW DULL AND DEPRESSING THE ENVIRONMENT FELT, AND IT MADE ME REALIZE HOW MUCH OF AN IMPACT COLOR AND DESIGN HAS ON THOSE THAT LIVE OR WORK IN A SPACE. BECAUSE OF THIS, I AM COMMITTED TO DESIGNING COLORFUL AND INNOVATIVE ENVIRONMENTS THAT PROMOTE A SENSE OF WELL-BEING AND ENCOURAGE COMMUNITY.

ADDITIONALLY, I HAVE SEVERAL YEARS OF WORK EXPERIENCE IN CREATIVE FIELDS. I SERVED AS A CREATIVE ARTS LEADER AT A SUMMER CAMP, INTERNED AT AN ARCHITECTURE AND DESIGN STUDIO, BOTH SUMMER AND WINTER OF 2025, AND HAVE WORKED IN THE MAKER LAB ON ACU'S CAMPUS FOR THE LAST THREE YEARS. ALSO, I OWN A BUSINESS AS A COMMISSIONED ARTIST IN WHICH I CREATE CUSTOM PIECES FOR CLIENTS TO BRING JOY TO THEIR LIVES. THESE EXPERIENCES HAVE STRENGTHENED MY LEADERSHIP, COLLABORATION SKILLS, AND PASSION AND EYE FOR DESIGN.

FUN FACTS ABOUT ME IS THAT I LOVE TRAVELING, LIVE MUSIC, AND THRIFTING. EXPLORING NEW PLACES BRINGS ME SO MUCH JOY AND FINDING THAT HIDDEN GEM IN A THRIFT STORE ALWAYS FEELS LIKE A MOMENT OF DISCOVERY. I AM AN EVER-CURIOUS CREATIVE CONTINUALLY SEEKING NEW INSPIRATION.



PERSONAL INFORMATION

ADDRESS

FLOWER MOUND, TX

CONTACT

AVA GRACE KOELE
AGK21D@ACU.EDU
214-984-1062

EDUCATION

ABILENE CHRISTIAN UNIVERSITY (CIDA ACCREDITED) / 3.93 GPA

CANDIDATE FOR B.S. IN INTERIOR DESIGN AND ASSOCIATE IN ARCHITECTURE
GRADUATION MAY 2026
DEAN'S LIST EVERY SEMESTER
MEMBER OF ASID AND ALPHA CHI HONOR SOCIETY

STUDY ABROAD

GERMANY 2023

PROFESSIONAL SKILLS

REVIT, AUTOCAD, LUMION, TWINMOTION, ADOBE ILLUSTRATOR, MICROSOFT OFFICE, BLUEBEAM,
SKETCHING AND HAND RENDERING, SPACE PLANNING, DESIGN DEVELOPMENT, FF&E SELECTION,
MATERIAL AND FINISH SCHEDULES, COLOR THEORY, CLIENT PRESENTATIONS, ADA AND BUILDING
CODES, 3D RENDERING/ MODELING, CNC ROUTER, LASER CUTTER, VINYL CUTTER, 3D PRINTER

TABLE OF CONTENTS

1

INTERNATIONAL RESIDENCE : DUBAI

2

CORPORATE DESIGN : WETHINK

3

CORPORATE DESIGN : ACU - PRESIDENT'S OFFICE

4

NEIGHBORHOOD PARK : ROANOKE, TX

5

HEALTHCARE DESIGN: HENDRICK ONCOLOGY CENTER

6

FURNITURE DESIGN : CHAIR

7

LIGHTING DESIGN : TABLE LAMP

INTERNATIONAL RESIDENCE : DUBAI

CLIENT

BILAL AND ZAHRA SHARIF

FAITH : DEVOUT MUSLIMS

DESIGN PREFERENCES

- TRADITIONAL, FAMILY-ORIENTED DESIGN
- AMPLE SPACE FOR GUESTS
- HAND CARVED, WOOD FURNITURE
- CALM AND WELCOMING ENVIRONMENT

RESEARCH

TRADITIONAL COLORS : BLUE, GREEN, WHITE, GOLD

CLOSED CONCEPT KITCHEN

- KEEPS STRONG SMELLS FROM SPREADING
- PREVENTS GUESTS FROM SEEING CLUTTER OF FOOD PREPARATION

TWO SEPARATE TOILET ROOMS IN PRIMARY BATH

- MAINTAINS PRIVACY AND CLEANLINESS

MAID HAS OWN PRIVATE QUARTERS

- PRIVACY FROM FAMILY

PRAYER ROOM

- BLUE IS ASSOCIATED WITH CONTEMPLATION AND IS A SYMBOL OF SPIRITUALITY
- MATS ARE FACING MECCA (QIBLA)

INHABITANTS

- THE MARRIED COUPLE
- 4 CHILDREN (1, 5, 10, AND 14 YEARS OLD)
- A LIVE-IN MAID

PROMPT : DESIGN A FAMILY ORIENTED AND TRADITIONAL STYLE APARTMENT INCORPORATING ISLAMIC ARCHITECTURAL ELEMENTS

SOLUTION : A WELCOMING HIGHRISE APARTMENT DESIGN WITH TRADITIONAL COLORS, INCORPORATION OF DARK, HAND CARVED WOOD FURNITURE, ACCOMMODATIONS FOR ALL RESIDENTS, AND AMPLE SPACE FOR VISITORS

PROCESS WORK

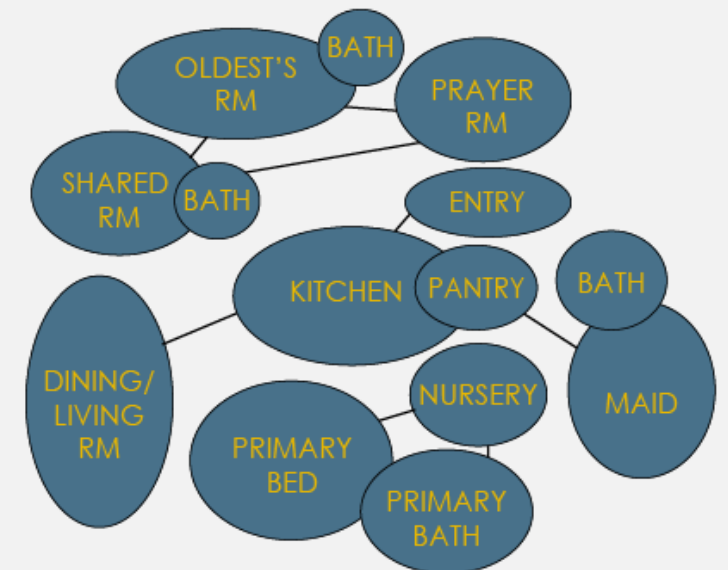
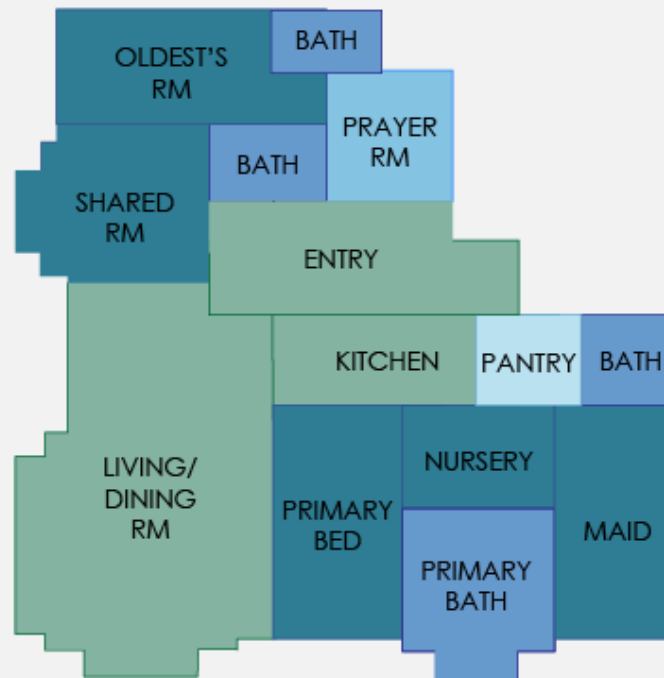

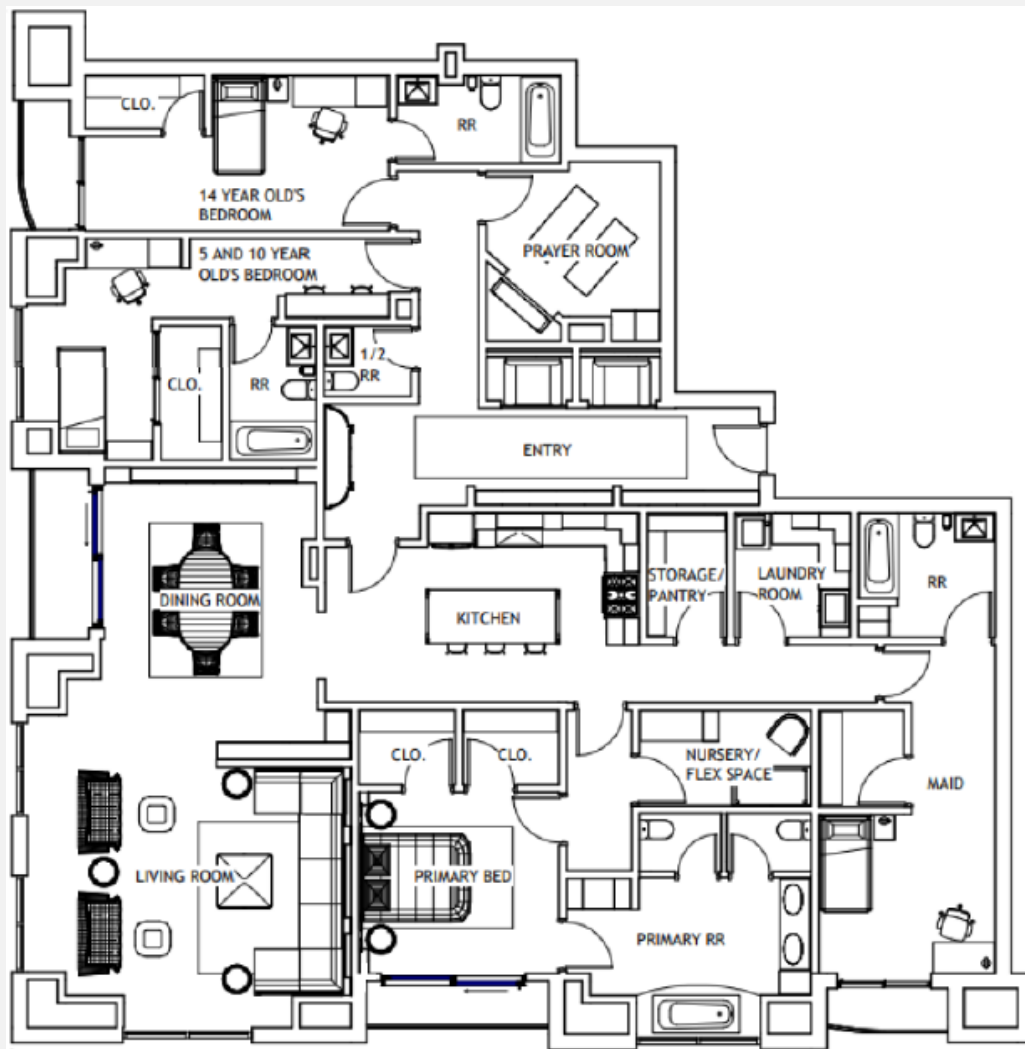

FOR THIS APARTMENT IN DUBAI, THE CLIENT REQUESTED THAT THE DESIGN BE TRADITIONAL, FAMILY-ORIENTED, AND SPECIFICALLY NOTED THE NEED FOR HAND CARVED WOOD FURNITURE. THIS DESIGN INCLUDES THE 4 CORE COLORS THAT ARE SIGNIFICANT IN ISLAMIC ARCHITECTURE. THESE COLORS ARE WELCOMING AND ALLOW FOR A CALMING ATMOSPHERE.

PAIRING WELL WITH TRADITION, IS THE DARK CHERRY WOOD FURNITURE THAT BRINGS A WARMTH AND SENSE OF LIFE TO THE DESIGN. TRADITIONAL PATTERNS BRING A NEEDED POSITIVE ENERGY AND GRACE THE SPACES THROUGH RUGS AND TILEWORK.

THE MATERIALS AND FINISHES WORK IN HARMONY TO CREATE A VIBRANT, CALMING, AND FRIENDLY ENVIRONMENT FOR THE INHABITANTS AND GUESTS ALIKE.



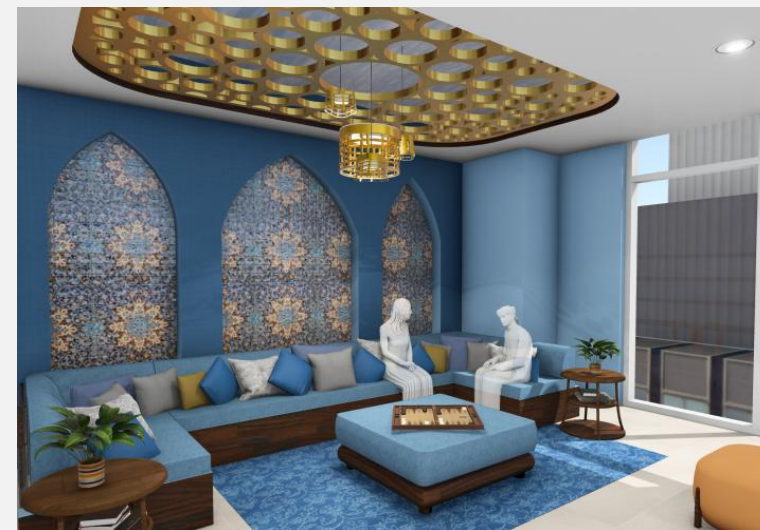

FALL 2025

DESIGNED USING
REVIT AND LUMION

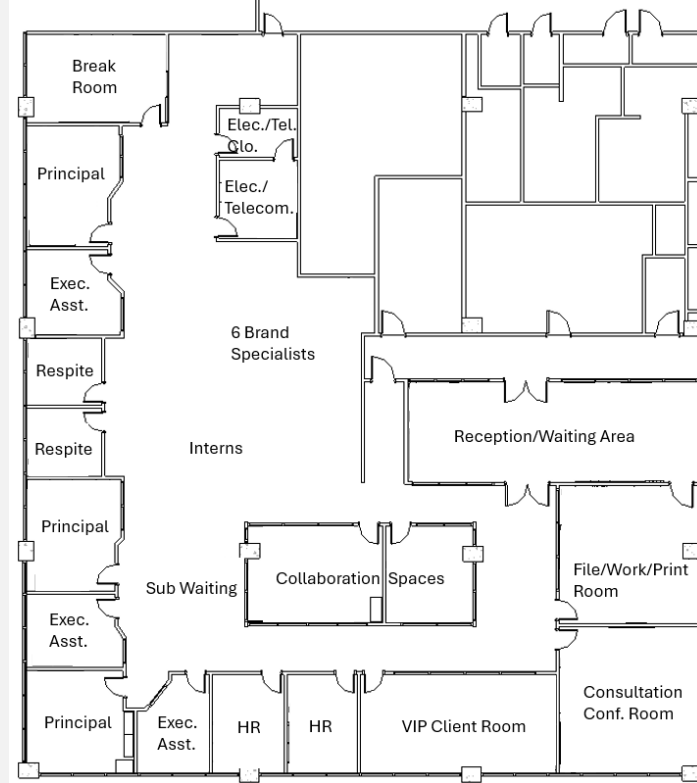
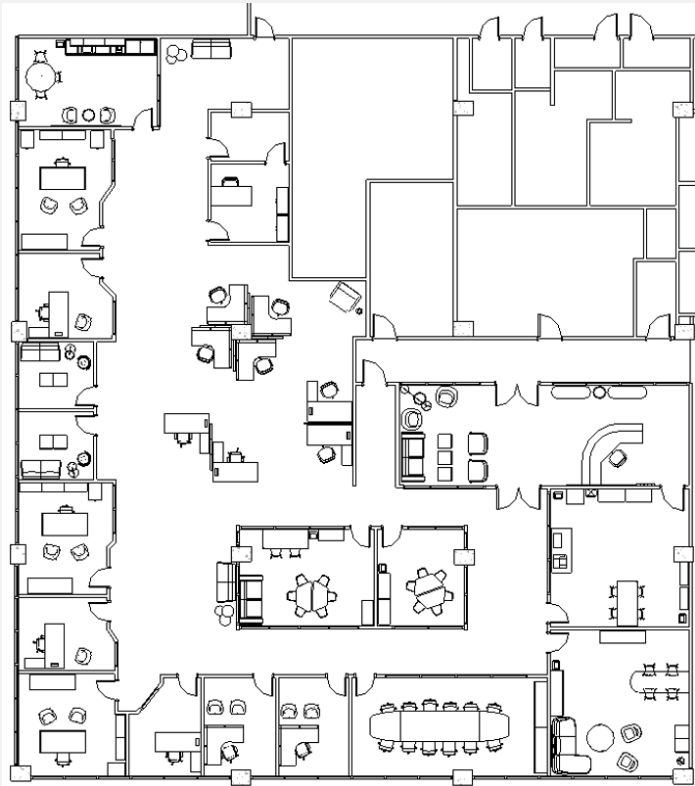

PROMPT : ORGANIZE AN OFFICE FLOOR PLAN BASED ON A LIST OF REQUIRED ROOMS AND ELEMENTS

SOLUTION : A VIBRANT AND ENERGIZING OFFICE ENVIRONMENT THAT WILL SPARK PRODUCTIVITY, DUE TO COLOR SELECTION, WHILE MEETING THE PROJECT'S SPACE REQUIREMENTS

FOR THIS OFFICE SPACE, MY GOAL WAS TO CREATE AN ENVIRONMENT THAT IS EASY TO NAVIGATE AND WORK IN. THIS CAN BE ACCOMPLISHED IN VARIOUS WAYS, ONE OF WHICH INVOLVES BRIGHTER COLORS AND OPTIMIZATION OF NATURAL LIGHT. HAVING A VIBRANT SPACE WILL SPARK PRODUCTIVITY AND ENERGIZE THE USER.

THE OVERALL OUTCOME OF THIS SPECIFIC DESIGN CONCEPT IS AN INNOVATIVE AND COLLABORATIVE SPACE IN WHICH EMPLOYEES AND CLIENTS ARE EMPOWERED AND DRIVEN TO BE PRODUCTIVE.



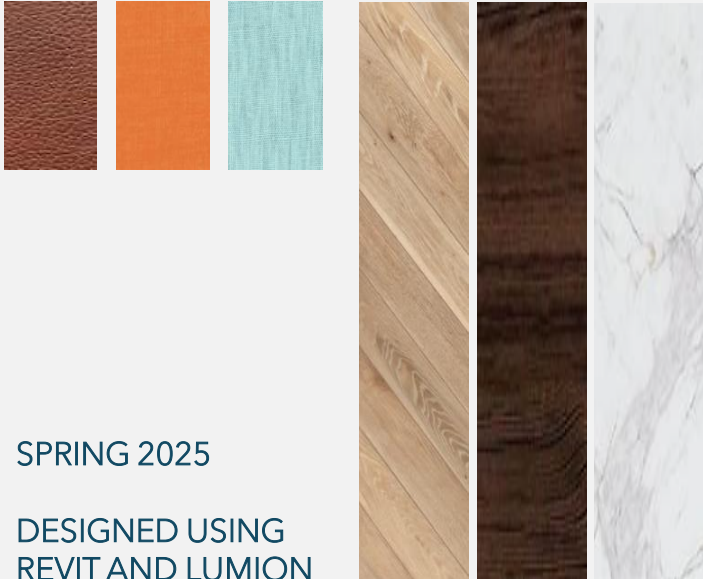

SPRING 2025

DESIGNED USING
REVIT AND LUMION

CORPORATE DESIGN : ACU – PRESIDENT’S OFFICE

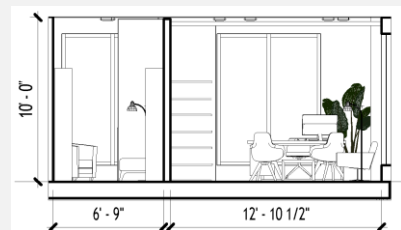
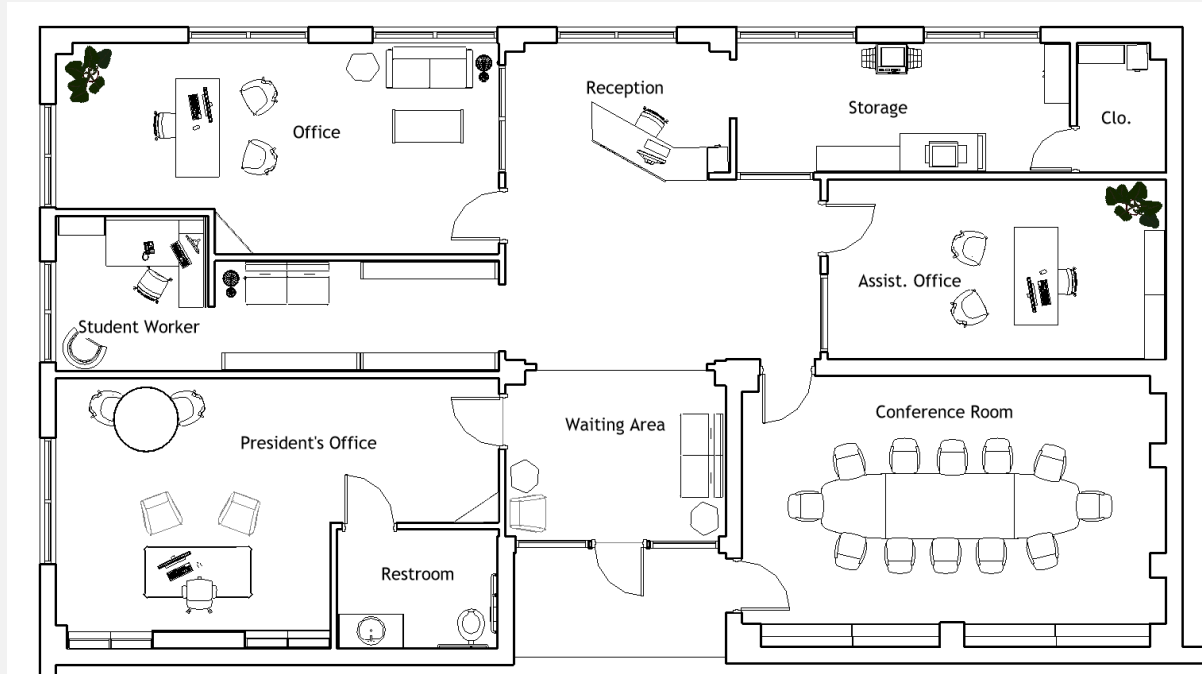

STUDENT
WORKER

OFFICE

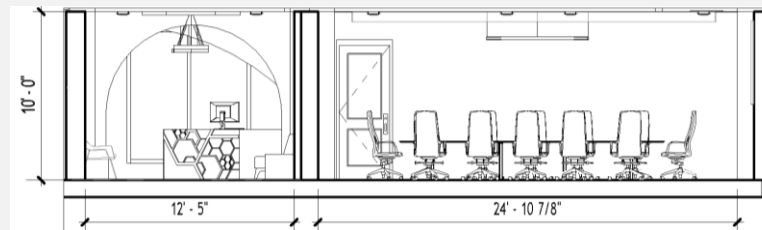

WAITING
AREA

CONFERENCE
ROOM

PROMPT : CREATE A MODERN REDESIGN OF AN EXISTING OFFICE ON ACU'S CAMPUS

SOLUTION : A BRIGHT AND INSPIRING OFFICE ATMOSPHERE, THAT MEETS THE NEEDS OF THE USERS AND VISITORS, WHILE REPRESENTING THE UNIVERSITY'S CORE VALUES

MY GOAL FOR THE PRESIDENT'S OFFICE AIMS TO EMBODY A CALMING AND FRIENDLY ATMOSPHERE WHILE RADIATING PROFESSIONALISM AS WELL AS REFLECT THE STUDIOUS NATURE OF ITS SURROUNDINGS. THIS SPACE IS A BLEND OF THE MODERN AND TRADITIONAL, ALLOWING THE AESTHETICS TO WORK IN HARMONY WITH EACH OTHER IN A FUNCTIONAL AND VISUALLY PLEASING WAY, INSPIRING INNOVATION, PRODUCTIVITY, AND CONFIDENCE. THE DESIGN'S MAIN FOCUS IS TO FOSTER A SENSE OF FRIENDLINESS AND APPROACHABILITY THROUGH CAREFULLY CHOSEN MATERIALS, LIGHTING, AND FURNISHINGS.

THROUGHOUT THE SPACE, A LIGHTER COLOR PALETTE OF MUTED TONES PAIRED WITH POPS OF DARKER COLORS, SHAPE THE BRIGHT AND THOUGHTFUL MOOD OF THE VARIOUS AREAS OF THE OFFICE. THIS VISION AND DESIGN FOR THE PRESIDENT'S OFFICE WILL MEET THE VARIOUS NEEDS OF THE USERS AND VISITORS, PROVIDING GREAT FUNCTIONALITY AND WELL-BALANCED ATMOSPHERE, AND WILL REPRESENT THE UNIVERSITY'S CORE OF EXCELLENCE AND PRESERVATION OF TRADITIONAL VALUES.



SPRING 2025

DESIGNED USING
REVIT AND LUMION

NEIGHBORHOOD PARK : ROANOKE, TX

SUMMER 2025 : INTERNSHIP WITH RGA ARCHITECTS
SITE LOCATION : ROANOKE, TX

AS A CO-LEADER OF A 5-INTERN TEAM, MY RESPONSIBILITIES INCLUDED RESEARCHING EQUIPMENT AND LANDSCAPING, MAJOR DESIGN CONCEPT DEVELOPMENT, AND DESIGN AND PRODUCTION OF PRESENTATION BOARDS. MY SOLE RESPONSIBILITY WAS MODELING THE ENTIRE PARK IN REVIT, WHICH WAS THEN READY TO BE RENDERED.

AS A TEAM, WE PRESENTED OUR CONCEPT TO OFFICIALS AT CITY HALL IN ROANOKE, AT THE END OF THE SUMMER.

EARLY SKETCHES

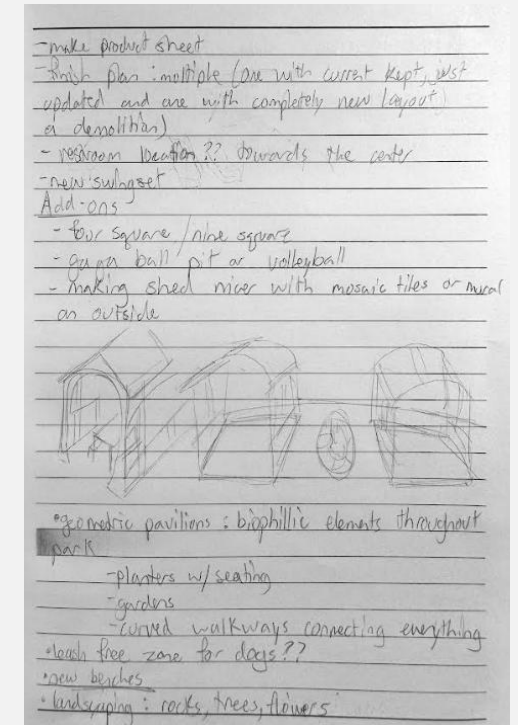
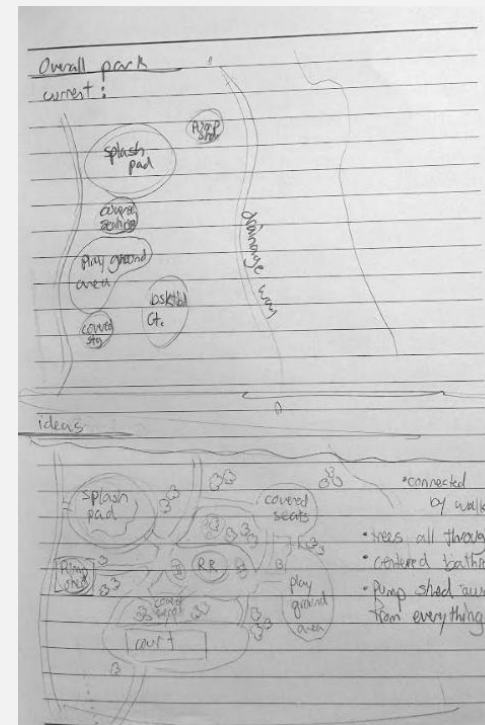
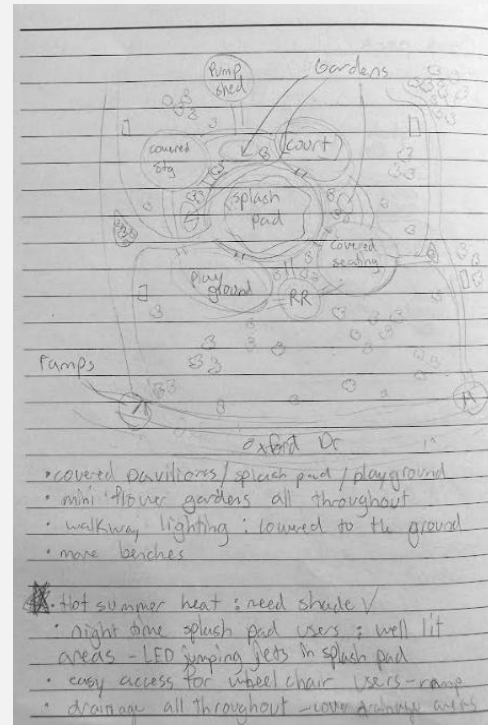
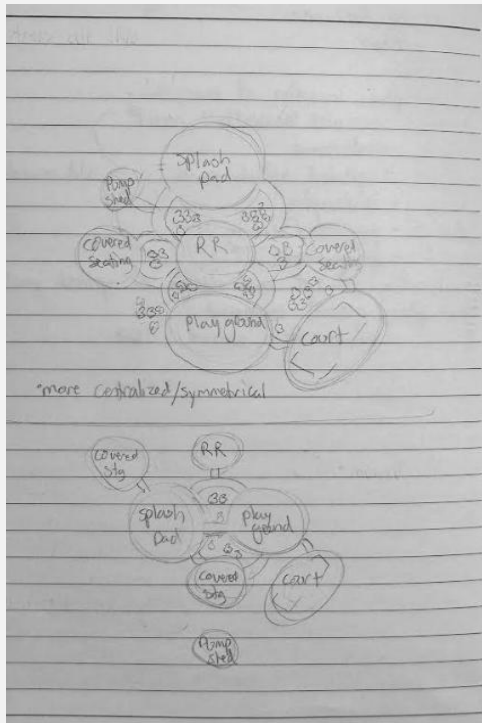

PROJECT : REVITALIZATION OF AN EXISTING CITY PARK WITH A SET PROJECT SCOPE AS PARAMETERS

SOLUTION : A COMMUNITY PARK DESIGN THAT IS FAMILY FRIENDLY AND ADA ACCESSIBLE, OFFERING A WIDE ARRAY OF ACTIVITIES AND AREAS FOR ALL AGES, WHICH INCLUDE A DOG PARK, SPORTS COURTS, A COVERED PLAYGROUND AND SPLASH PAD, A SENSORY GARDEN, AND A FOOD TRUCK AREA



MODELED IN REVIT
AND RENDERED IN
TWINMOTION

SPORTS COURTS PLAN

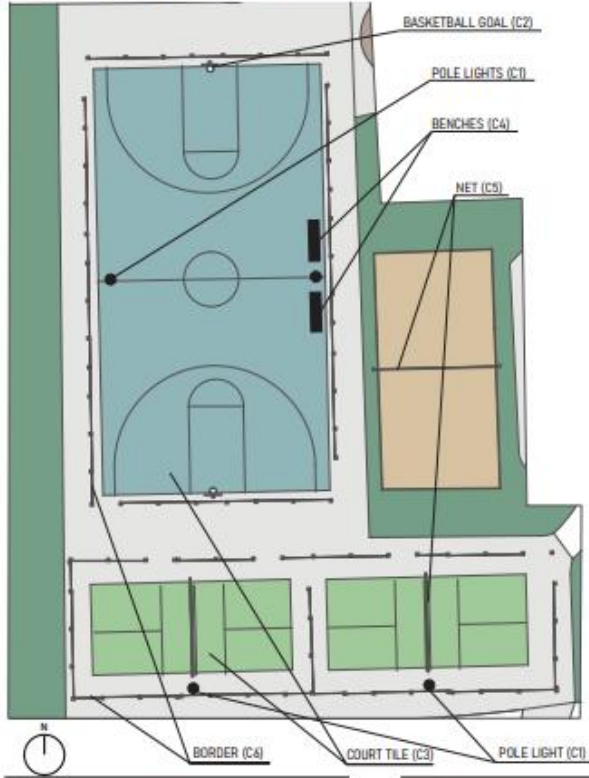

 Pole-top Laminaire C1	 Basketball Hoop C2
 Polypropylene Floor C3	 Generation 50 Bench C4
 Metallex C3	 Landscape Form C4
 Adjustable Net C5	 Rebounders C4
 Sportcourt C5	 Sportcourt C4

PARK AND SPLASH PAD PLAN

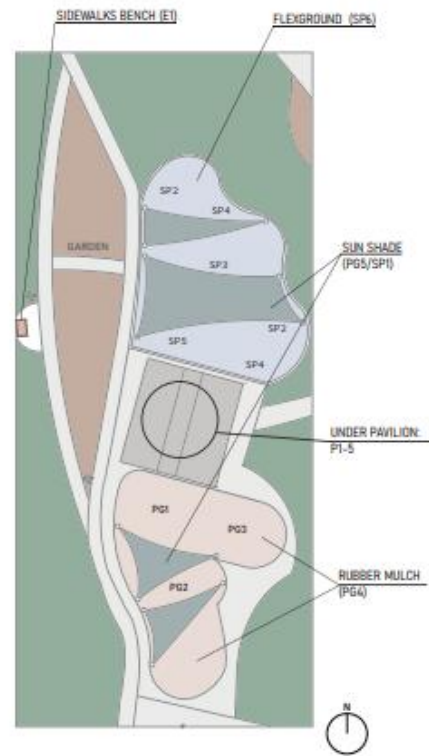

PARKS OF ROANOKE

 Accessible Wheel P01	 Playground P02	 Swingset P03	 Jelly Bean Rubber Mat P04
 Playworld P01	 Playworld P02	 Playworld P03	 Jelly Bean Rubber Mat P04
 Sun Shade P05	 Basketball Hoop with Acrylic P06	 Hydrakids 1 P07	 LED Triple Arch Jet P08
 USA Shade P09	 Aquatic SP1	 Aquatic SP2	 Aquatic SP3
 P010/SP1 P10	 Aquatic Surfacing P11	 Square Pavilion P12	 Safety Recycling System P13
 Aquatic by Landscape Structures SP1	 P014/SP1 SP1	 Landscape Form P1	 Landscape Form P2
 Boulder Posing Table P14	 Wall Laminaire P15	 Sluicel Pavilion P16	 Station Bench P17
 Landscape Form P1	 P14 P14	 Granger P15	 Landscape Form P1

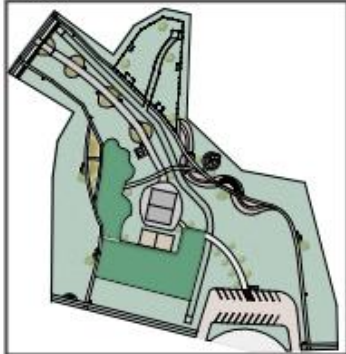

PRESENTATION BOARDS
CREATED IN ADOBE
ILLUSTRATOR

DOG PARK

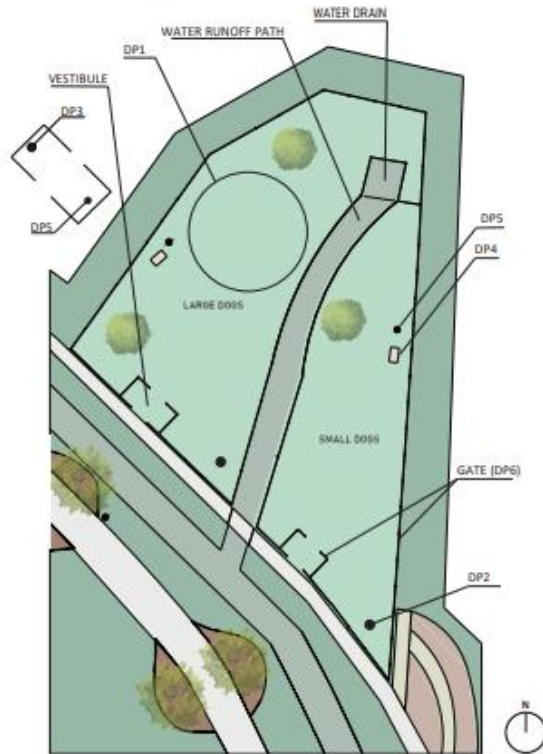

<p>Novice Dog Park</p> <p>ibpark Catalog DPI1</p>	<p>ELKAY Drinking Fountain</p> <p>Greinger DPI2</p>
<p>Standard Pet Waste Solutions</p> <p>BarcoProducts DPI3</p>	<p>Stretch Bench</p> <p>landscape forms DPI4</p>
<p>Ashberry Area Light</p> <p>landscape forms DPI5</p>	<p>LINE Fence</p> <p>landscape forms DPI6</p>

SENSORY GARDEN

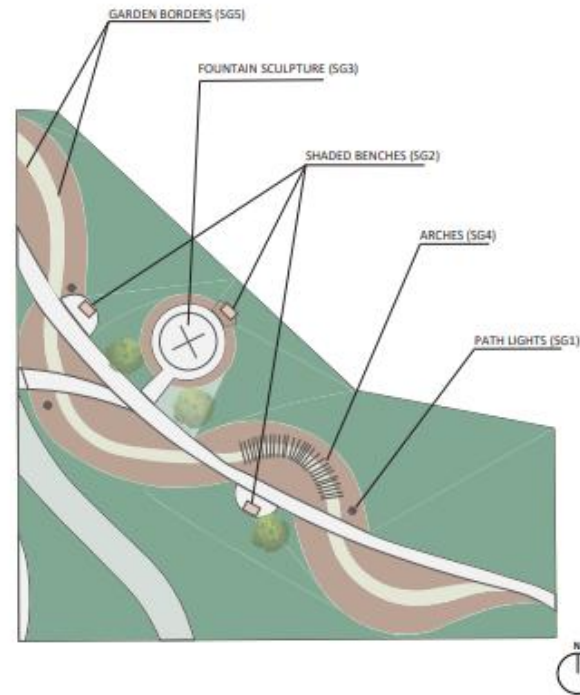

PARKS OF ROANOKE

<p>Arropolis Bollard</p> <p>landscape forms SG1</p>	<p>Kalidoscope OS</p> <p>landscape forms SG2</p>
<p>Fountain Sculpture</p> <p>mefalarisculpture.com SG3</p>	<p>Round Arch</p> <p>Agriframes SG4</p>
<p>Border Edging</p> <p>Agriframes SG5</p>	

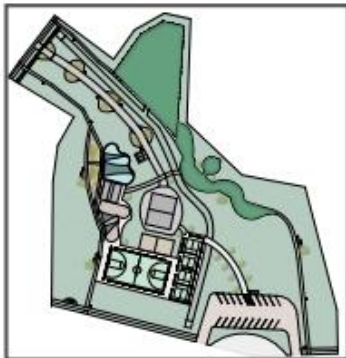

PRESENTATION BOARDS
CREATED IN ADOBE
ILLUSTRATOR

PAVILLION

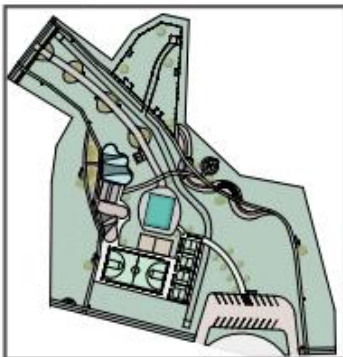
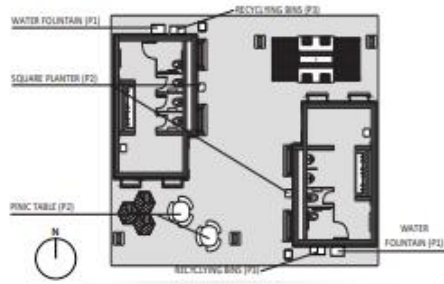

	
Granger P1	landscape forms P2
Select Recycling System	Gretchen Picnic Table
	
landscape forms P3	landscape forms P4
Wall Luminaire	Generation 50 Bench
	
BECA P5	landscape forms P6

RESTROOMS

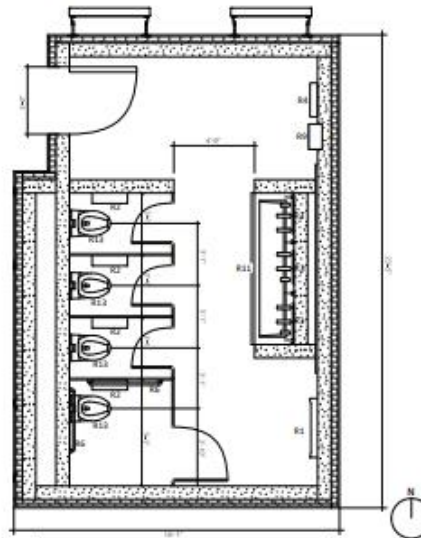

	
Sherrin Williams R16	Sherrin Williams R17

PARKS OF ROANOKE

		
Robrick R1	Robrick R2	Robrick R3
		
Robrick R4	Robrick R5	Robrick R6
		
Robrick R7	Robrick R8	Robrick R9
		
Robrick R10	SOAN R11	SOAN R12
		
American Standard R13	American Standard R14	AG R15

PRESENTATION BOARDS
CREATED IN ADOBE
ILLUSTRATOR

PROCESS WORK AND RESEARCH

INTERVIEWED THREE DIFFERENT PEOPLE, CANCER PATIENTS AND LOVED ONES, ABOUT THEIR PERSONAL EXPERIENCES WITH ONCOLOGY CENTERS. THIS RESEARCH WAS CRUCIAL IN CONFIRMING THE NECESSITY OF CALMING COLORS, AVOIDANCE OF A STERILE-FEELING ENVIRONMENT, AND INCLUSION OF MULTIPLE SEATING AREAS

CASE STUDIES : THOROUGHLY RESEARCHED MEDICAL FACILITIES FOR DESIGN CONCEPT INSPIRATION



PROMPT : CREATE A MODERN REDESIGN OF AN EXISTING ONCOLOGY CENTER IN ABILENE, TX

SOLUTION : A WELCOMING, ENCOURAGING, AND HEALING ONCOLOGY CENTER DESIGN CONCEPT THAT FOCUSES ON BRINGING THE OUTSIDE IN TO PROMOTE WELL-BEING. THIS IS ACCOMPLISHED THROUGH NATURAL WOODS, TERRARIUMS, AND A GREEN AND BLUE COLOR SCHEME

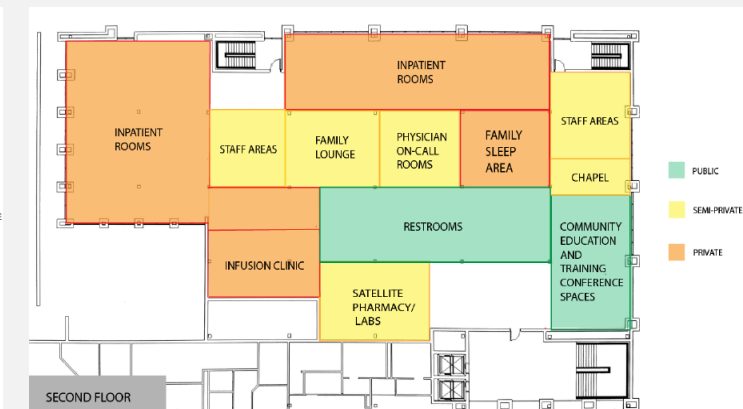
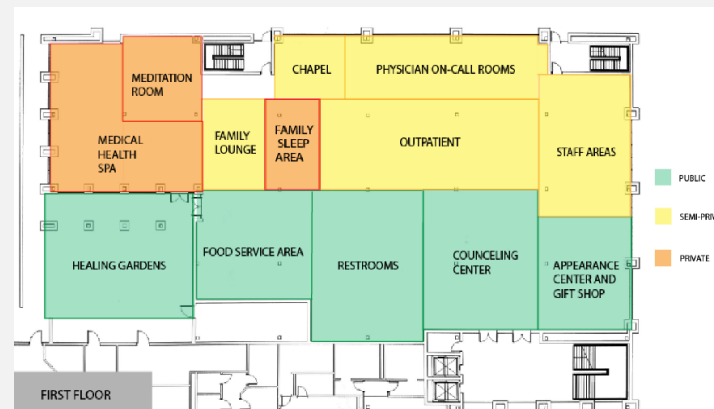
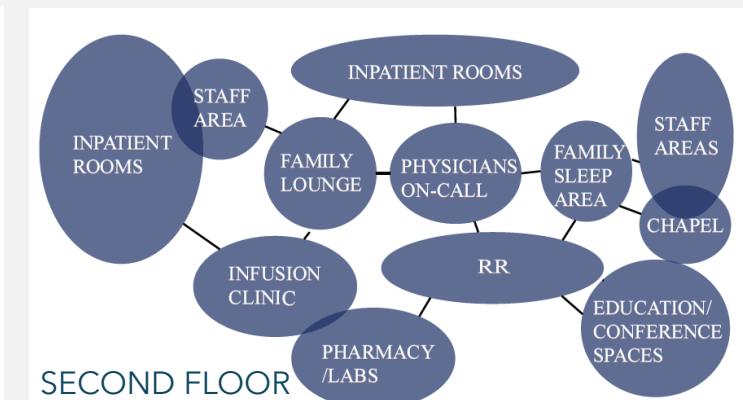
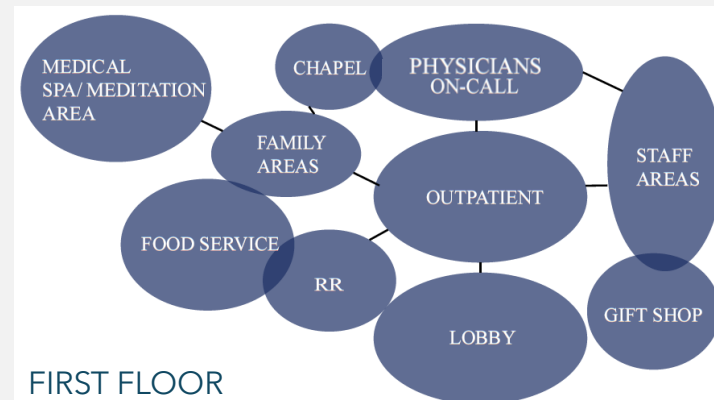

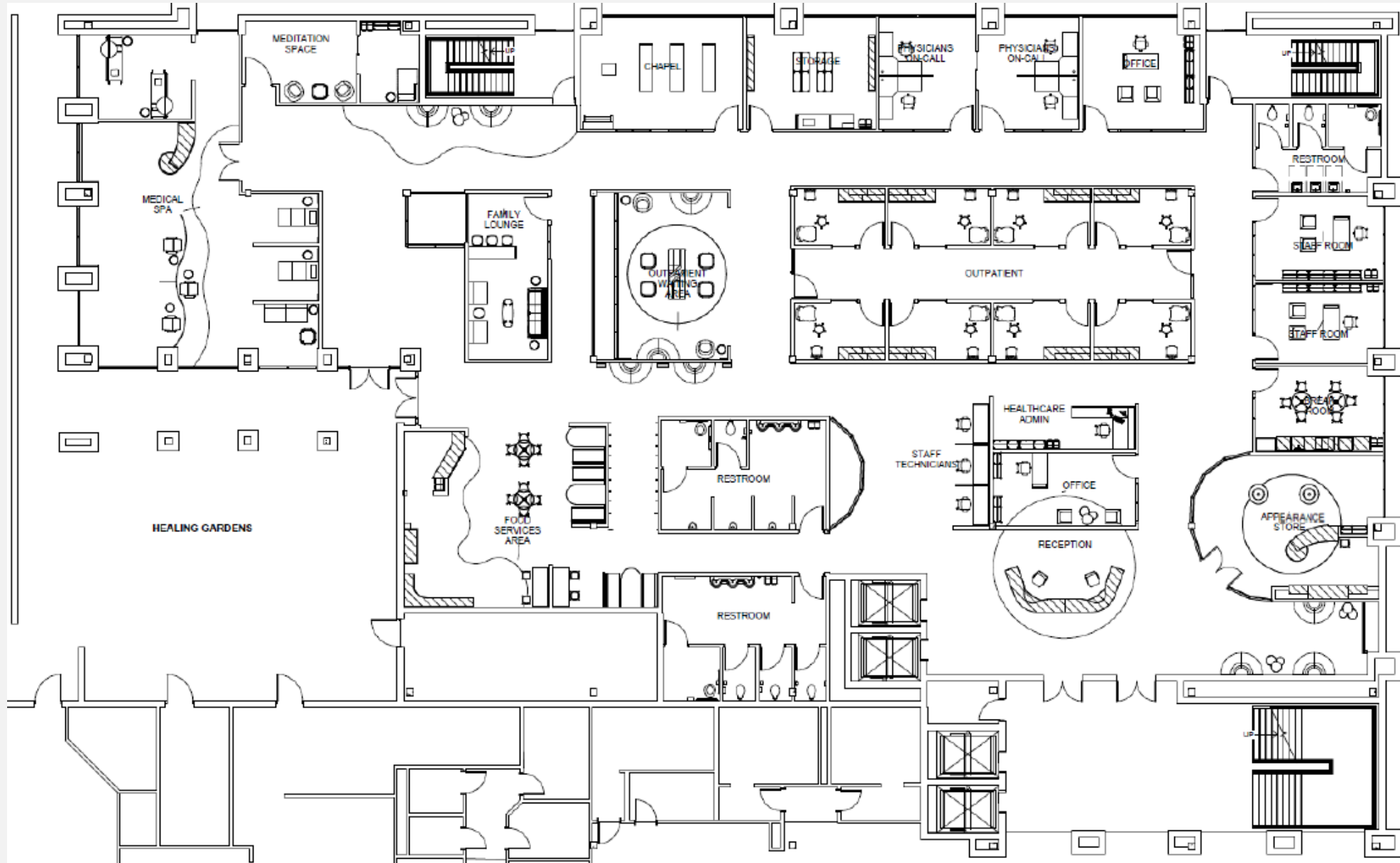

FIRST FLOOR

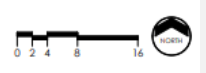

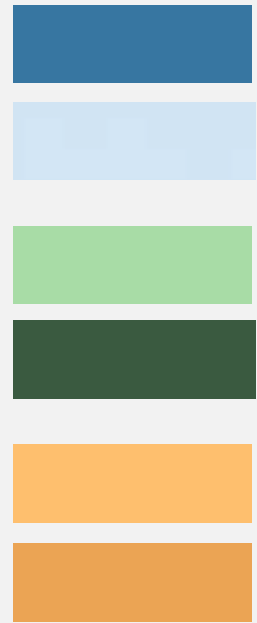
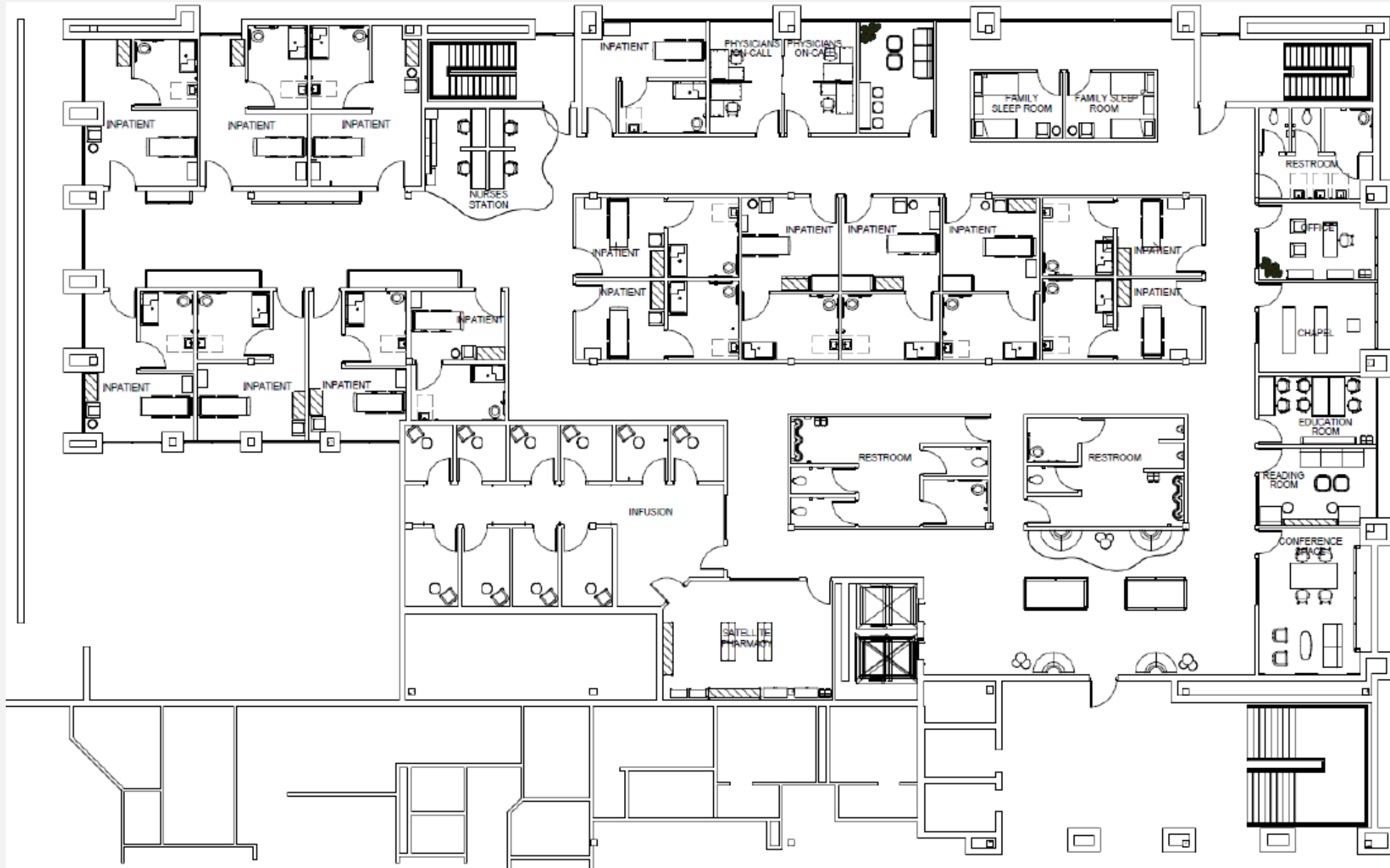

SECOND FLOOR



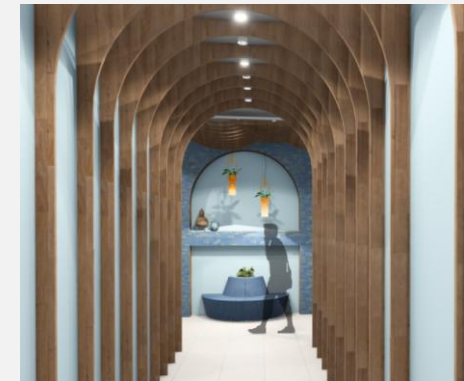

MY DESIGN IS GROUNDED IN THE CONCEPT OF NATURE, SPECIFICALLY A CALM RIVER. TO CREATE THIS WELCOMING ATMOSPHERE, NATURAL ELEMENTS ARE INCLUDED, SEEN IN WARM WOODS AND LUSH GREENERY. THIS BRINGS THE OUTDOORS IN AND AIDS IN STRESS REDUCTION AND HEALING. THE FLOW OF A RIVER IS SEEN IN THE LIGHT FIXTURES LINING THE HALLWAYS AND THE ROUNDED ARCHWAYS INCORPORATED THROUGHOUT THE FACILITY. A CHEERFUL AND SOOTHING COLOR SCHEME, LIKE ORANGE, GREEN, AND BLUE, PAINTS THE SPACES TO ENCOURAGE THE PATIENTS AND SPARK HOPE AND POSITIVITY. OVERALL, THIS DESIGN CREATES AN ENVIRONMENT WHERE BOTH PATIENTS AND STAFF ARE ENCOURAGED AND EMBOLDENED TO KEEP PUSHING FORWARD.

PARAMETERS : DESIGN AND BUILD A USABLE CHAIR THAT HOLDS AT LEAST 200 POUNDS USING ONE SHEET OF PLYWOOD AND NO NAILS

EARLY SKETCHES



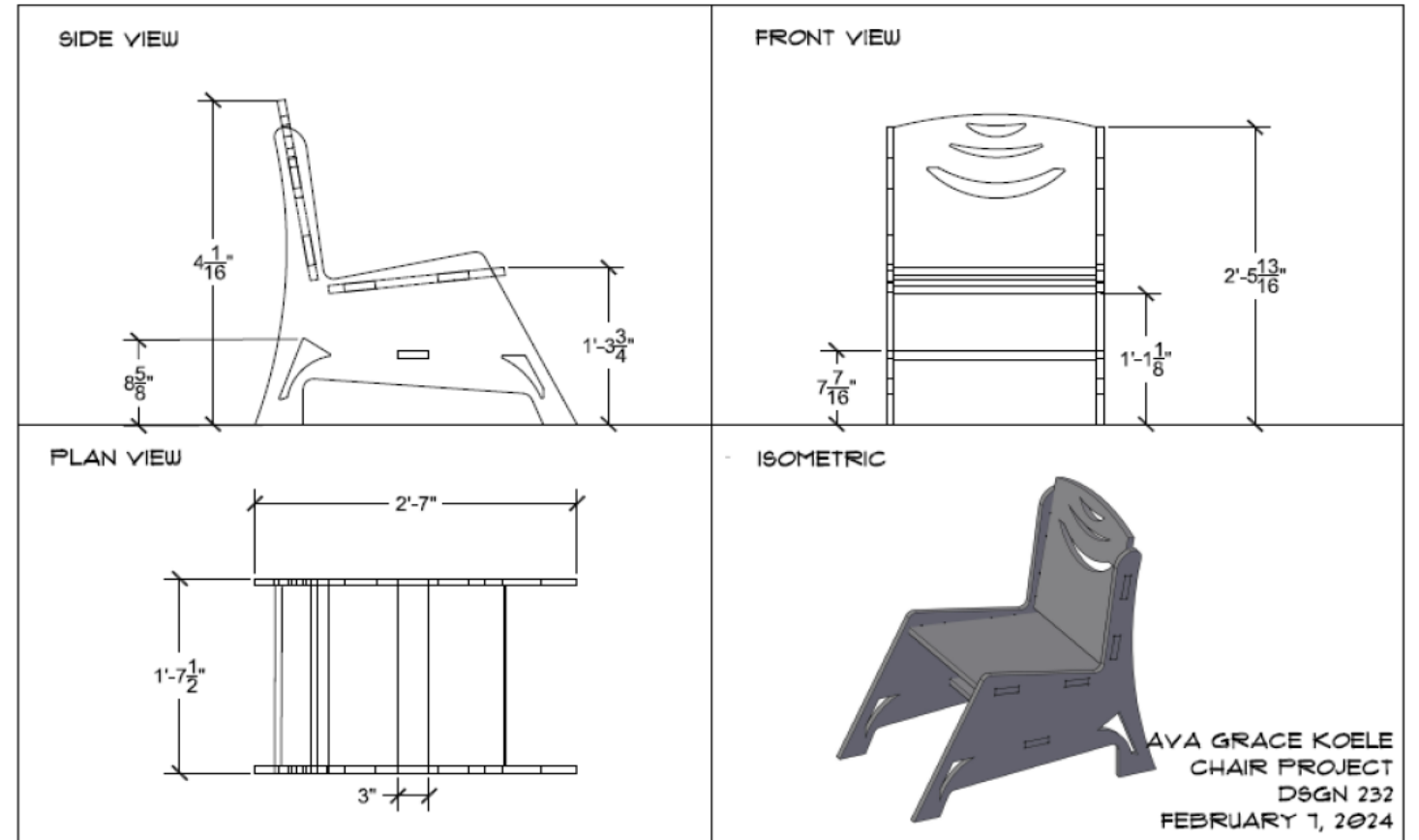

DESIGNED WITH AUTOCAD AND
CUT WITH A CNC ROUTER

EARLY SKETCHES

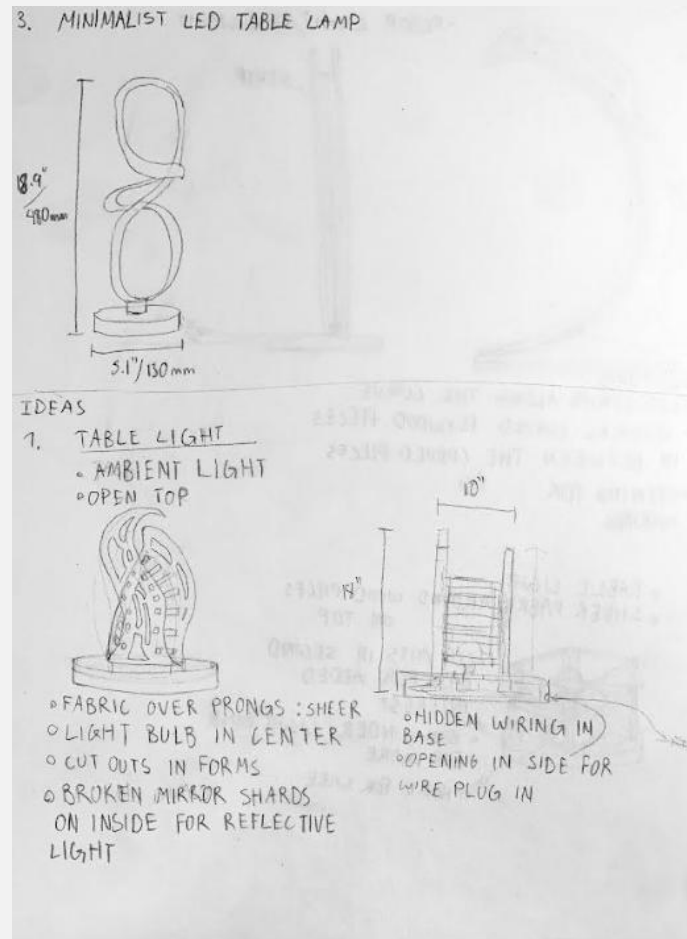
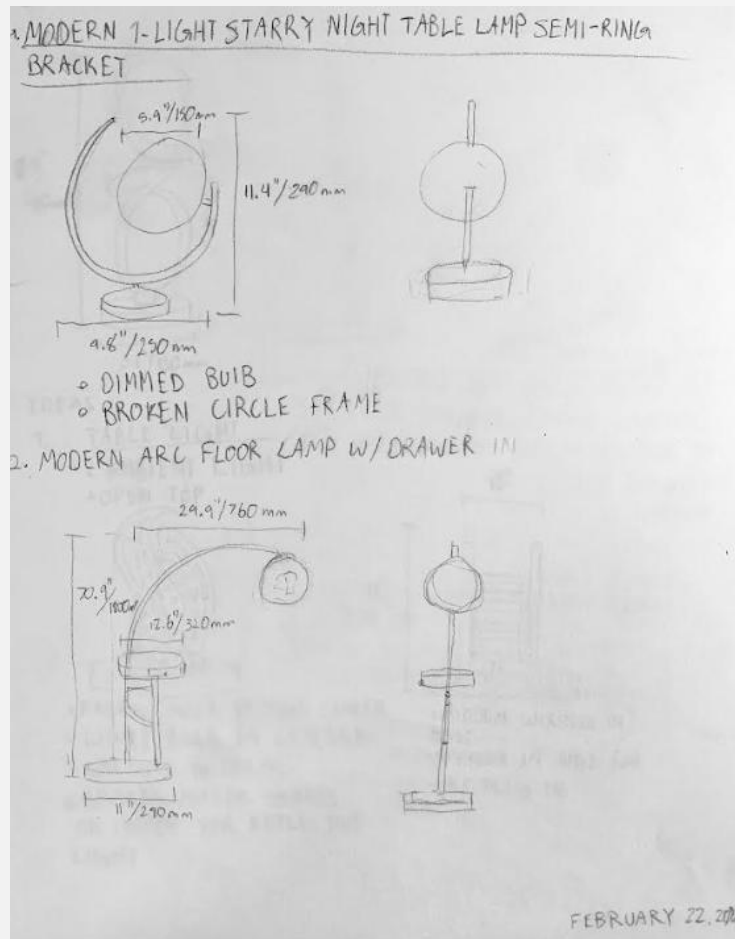

PARAMETERS : CREATE A WORKING LAMP USING ONE SHEET OF PLYWOOD, NO NAILS, AND ANOTHER MATERIAL OF CHOICE

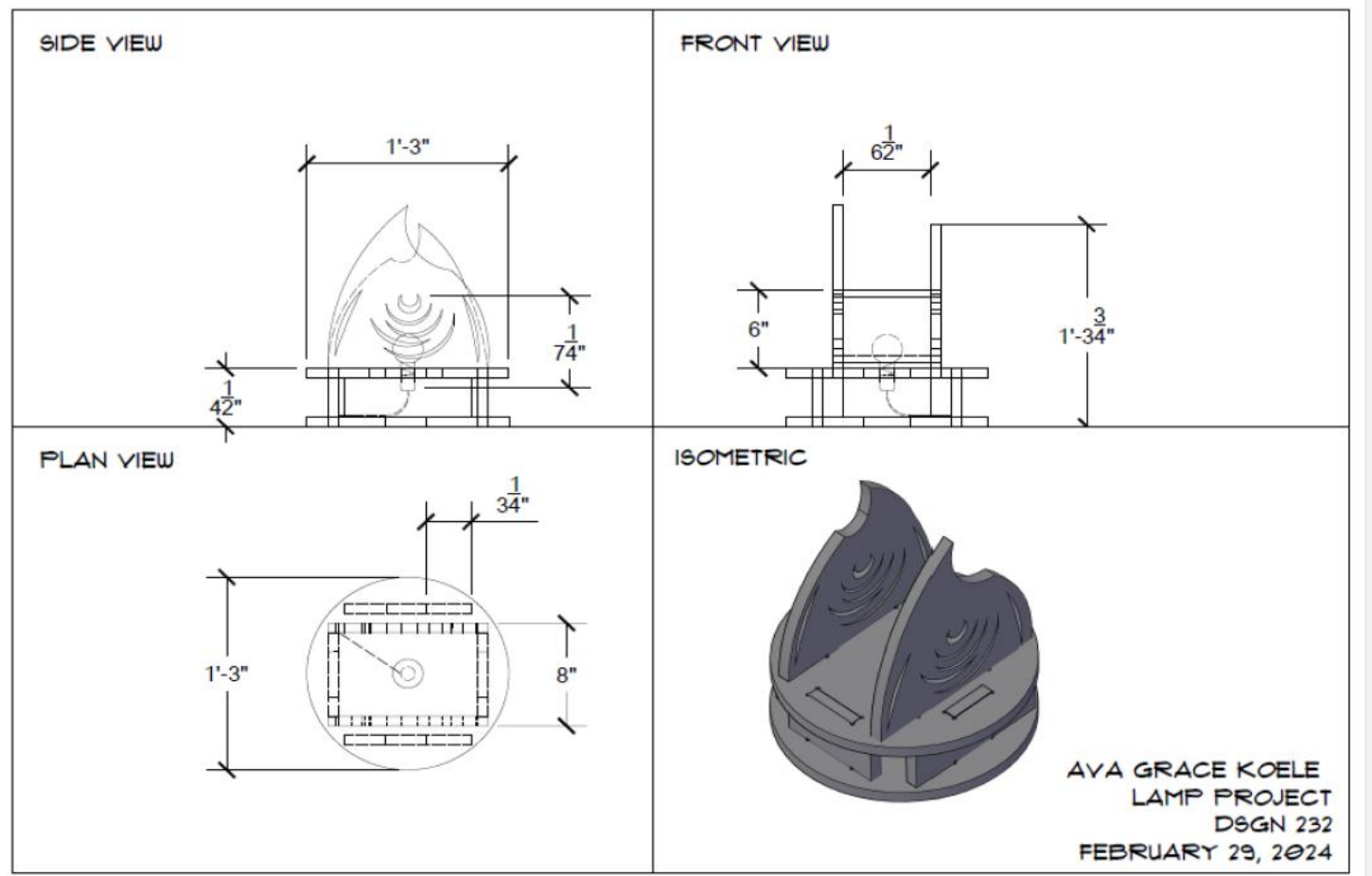

THANK YOU

AVA GRACE KOELE

